

# Technical Specifications

ENVIRONMENTAL CONDITIONS	
Ambient/storage temperature	0 ... +50°C/-25... +70°C
Max. relative humidity	80% Relative humidity for temperatures up to 31°C, decreasing linearly to 50% at 40°C.
Rated pollution degree	According to EN 60529 Front panel : IP60 Rear panel : IP20
Height	Max. 2000m

**⚠ Do not use the device in locations subject to corrosive and flammable gases.**

ELECTRICAL CHARACTERISTICS	
Supply	230V AC +%-10-%20 50/60Hz ; 10-30V DC / 8-24V AC SMPS
Power consumption	Max. 5VA
Wiring	2.5mm <sup>2</sup> screw-terminal connection.
Scale	0 ... 400°C
Sensitivity	1°C
Accuracy	For adjustment ±4%, for display ±0,5% (of full scale) or ±1 digit.
Display	3 digits, 7.6mm, 7 segment red LED
Data retention	EEPROM (at least 10 years)
EMC	EN 61326-1: 2013
Safety requirements	EN 61010-1: 2010 (Pollution degree 2, overvoltage category II)

OUTPUT	
Control output	Relay : 250V AC, 8A (for resistive load), NO+NC or 12V DC 20mA logic output
Life expectancy for relay	Mechanical 30.000.000 operation; electrical 300.000 operation

CONTROL	
Control type	Single-setpoint control
Control algorithm	On-Off / time proportional (optional)
A/D converter	10 bits
Proportional band	2% (for time proportional control)
Control period	10 second (for time proportional control)
Hysteresis	4°C (for On-Off control)

HOUSING	
Housing type	Suitable for flush-panel mounting.
Dimensions	W96xH96xD50mm
Weight	Approx. 250g (after packing)
Enclosure material	Self extinguishing plastics

**⚠ While cleaning the device, solvents (thinner, gasoline, acid etc.) or corrosive materials must not be used.**

## Dimensions

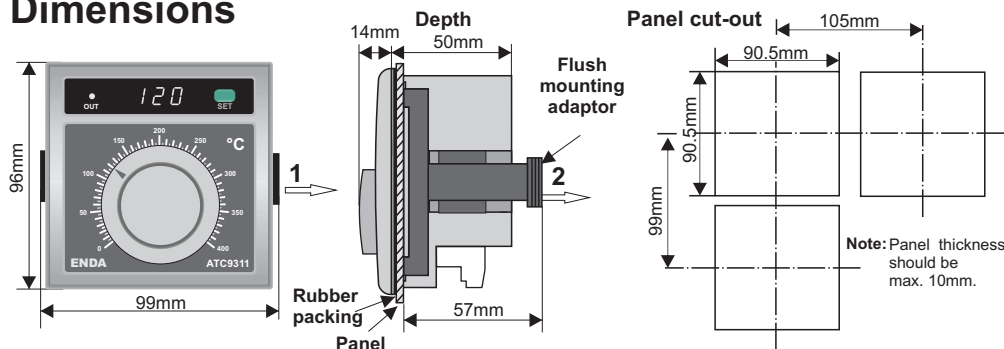

**For removing mounting clamps :** Push out the flush-mounting clamp in direction 1 as shown in the figure above. Then, pull out the clamp in direction 2. If there is no 60mm free space at back side of the device, it would be difficult to remove it from the panel.



Read this document carefully before using this device. The guarantee will be expired by damaging of the device if you don't attend to the directions in the user manual. Also we don't accept any compensations for personal injury, material damage or capital disadvantages.

# ENDA ATC9311

## ANALOG THERMOSTAT with DIGITAL DISPLAY

Thank you for choosing ENDA ATC9311



Order Code : ATC9311 - <input type="checkbox"/> 1 - <input type="checkbox"/> 2	
<b>1- Supply Voltage</b> 230.....230V AC  LV..... 10-30V DC / 8-24V AC	<b>2 - Sensor Type</b> FE....Fe-Const400°C  K.....NiCr-Ni 400°C

- \* 96 x 96mm sized.
- \* Digital display for measured temperature and set value.
- \* Selectable On-Off or time proportional control.
- \* Fe-Const thermocouple or NiCr-Ni thermocouple input.
- \* Output relay is de-energized in the case of sensor failure.
- \* Easy setting procedure.
- \* CE marked according to European Norms.



SİSEL MÜHENDİSLİK ELEKTRONİK SAN. VE TİC. A.Ş.  
Şerifali Mah. Barbaros Cad. No:18 Y.Dudullu 34775  
ÜMRANİYE/İSTANBUL-TURKEY  
Tel : +90 216 499 46 64 Pbx. Fax : +90 216 365 74 01  
url : www.enda.com.tr

**ENDA™**  
ATC9311-EN-08-220103

# ATC9311 Programming Diagram

## For displaying Set value

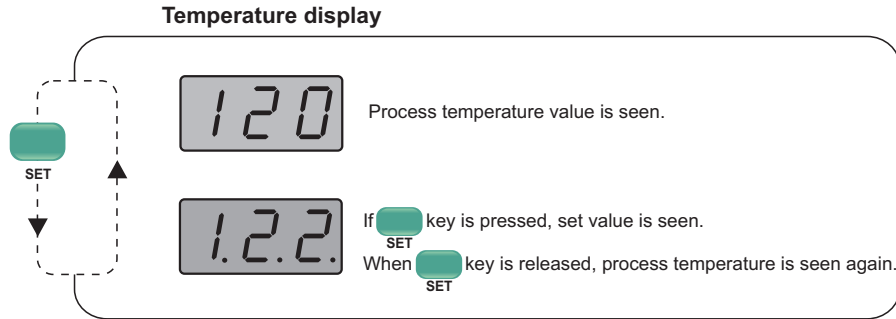

## For selecting control form.

When the device is energized, selected control form is seen on the display.

If time proportional control was selected, **TP** is seen.

If On-Off control was selected, **on-** and **off** are seen.

If the device is energized while holding **SET** key, control form changes and the related message is seen on the display.

## Error Messages

**PFA** If this message is seen, it means temperature sensor was not disconnected or over temperature condition was occurred. When this message is seen, the control output is de-energized.

**Err** If this message is seen, it means the device has a calibration error. In this case, the device should be sent to **Sisel A.Ş.** or to a nearest **ENDA** local representative for calibration and testing. When this message is seen, the control output is de-energized.

## Applications

Plastic injection presses, automatic bread making ovens, nylon bag machines, shrink packing machines, furniture presses, industrial ovens, textile machines, ironing presses and other temperature control applications.

## Connection diagram



**ENDAATC9311** is intended for installation in control panels. Make sure that the device is used only for intended purpose. The electrical connections must be carried on by a qualified staff and must be according to the relevant locally applicable regulations. During an installation, all of the cables that are connected to the device must be free of energy. The device must be protected against inadmissible humidity, vibrations, severe soiling and make sure that the operation temperature is not exceeded. All input and output lines that are not connected to the supply network must be laid out as shielded and twisted cables. These cables should not be close to the power cables or components. The shielding must be grounded on the instrument side.

### Terminal connection

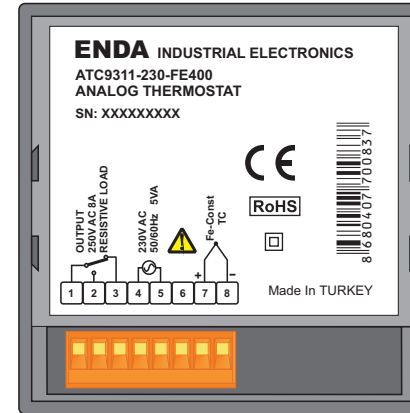

### Terminal connection

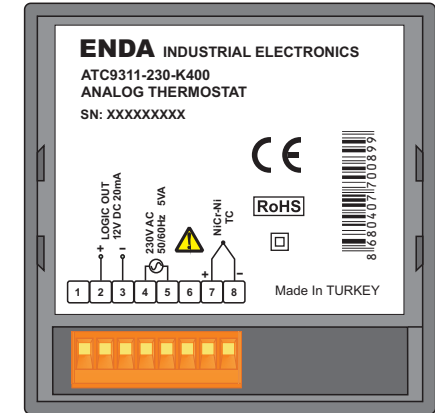

Logic output is not isolated from the inner circuits of the device. Therefore, when using a grounding thermocouple, do not connect the logic output terminals to the ground.



Holding screw 0.4-0.5Nm Equipment is protected throughout by DOUBLE INSULATION.

### NOTE :

#### SUPPLY :

184-253V AC  
or  
10-30V DC /  
8-24V AC  
50/60Hz 5VA

#### SENSOR INPUT:

Use suitable compensation cables. Do not use jointed cables. Pay attention to the polarities of the thermocouple cables as shown in the figure right.

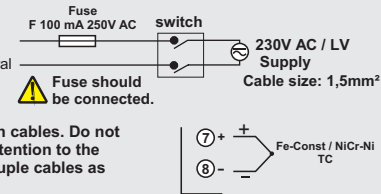

- Note :**
- 1) Mains supply cords shall meet the requirements of IEC 60227 or IEC 60245.
  - 2) In accordance with the safety regulations, the power supply switch shall bring the identification of the relevant instrument and it should be easily accessible by the operator.