



Please read this document carefully before using this product. The guarantee will be invalidated if the device is damaged by not following instructions detailed in the manual. The company shall not be responsible for any damage or losses however caused, which may be experienced as a result of the installation or use of this product.

ENDA ET5412 TEMPERATURE CONTROLLER

Thank you for choosing ENDA ET5412 temperature controller.

- ▶ 54x94mm sized.
- ▶ On-Off control.
- ▶ Relay output selection for cooling or heating control.
- ▶ Relay output for Alarm
- ▶ Single NTC probe input.
- ▶ Offset value can be entered for NTC probe.
- ▶ The output state can be set to ON, OFF or Periodical running in case of probe failure.
- ▶ Upper and lower limits of the setpoint can be set.
- ▶ Upper and lower alarm limits can be set to dependent on the setpoint value.
- ▶ Temperature unit can be selected as °C or °F.
- ▶ Communication feature over RS485 Modbus protocol (Specify at Order).
- ▶ CE marked according to European Norms.

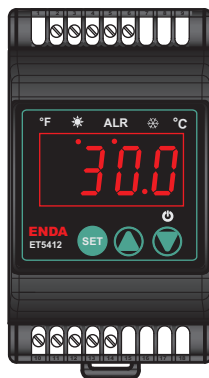

Order Code : ET5412 - -

1-Supply Voltage

230.....230V AC

LV..... 10-30V DC /
8-24V AC

2-Modbus

RS...Modbus

(Specify at Order)



ENDA ET5412 is a rail mounted device. Make sure that the device is used only for intended purpose. The electrical connections must be carried out by a qualified staff and must be according to the relevant locally applicable regulations. During an installation, all of the cables that are connected to the device must be free of electrical power. The device must be protected against inadmissible humidity, vibrations, severe soiling and make sure that the operation temperature is not exceeded. The cables should not be close to the power cables or components.

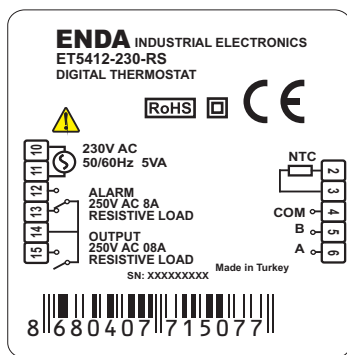
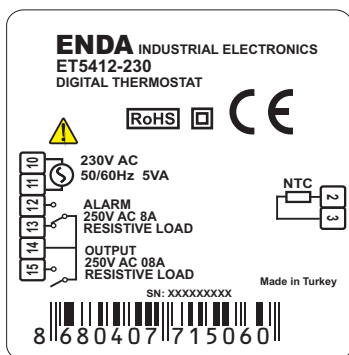

Holding screw
0.4-0.5Nm.

Equipment is protected
throughout by **DOUBLE
INSULATION**

NOTE:

SUPPLY:

184-253V AC
10-30V DC /
8-24V AC
50/60Hz 5VA

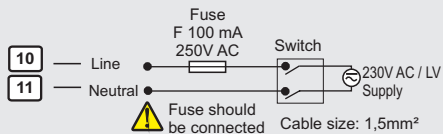

Note:

- 1) Mains supply cords shall meet the requirements of IEC 60227 or IEC 60245.
- 2) In accordance with the safety regulations, the power supply switch shall bring the identification of the relevant instrument and it should be easily accessible by the operator.

ENVIRONMENTAL CONDITIONS

Ambient / Storage Temperature	0 ... +50°C/-25 ... 70°C (without icing)
Relative Humidity	Max. humidity 80% for temperatures up to 31°C decreasing linearly to 50% relative humidity at 40°C.
Protection Class	According to EN60529; Front panel : IP65, Rear panel : IP20
Height	Max. 2000m

KEEP AWAY device from exposed to **corrosive, volatile and flammable gases or liquids and DO NOT USE** the device in similar hazardous locations.

ELECTRICAL CHARACTERISTICS

Supply voltage	230V AC 50/60Hz; 10-30V DC/8-24V AC SMPS
Power Consumption	Max. 5VA
Connection	2.5mm² screw-terminal connections
Scale	-60.0 ... +150.0°C (-76.0 ... +302.0°F)
Sensitivity	0.1°C (can be set as 0.1°C or 1°C.)
Accuracy	±1°C
Time Accuracy	±%1
Display	4 digits, 12.5mm, 7 segment LED
EMC	EN 61326-1: 2013
Safety Requirements	EN 61010-1: 2010 (Pollution degree 2, overvoltage category II)

OUTPUTS

Relay Output	OUTPUT : 250V AC, 8A (for resistive load), ALARM : 250V AC, 8A (for resistive load), NO., Control output. NO.+NC., Control output.
Life Expectancy for Relay	Mechanical 30.000.000; Electrical 300.00operation. 250V AC, 8A (resistive load).

CONTROL

Control Type	Single set-point control
Control Algorithm	On-Off control
Hysteresis	Adjustable between 1 ... 20.0°C.

HOUSING

Housing Type	Mounted to TH35 type rail that is in accordance with EN60715 standarts
Dimensions	W54xH94xD68mm
Weight	Approx. 190g (After packing)
Enclosure Material	Self extinguishing plastics.

Avoid any liquid contact while the device is switched on.
DO NOT clean the device with solvent (thinner, gasoline, acid etc.) and / or abrasive cleaning agents.

DIMENSIONS

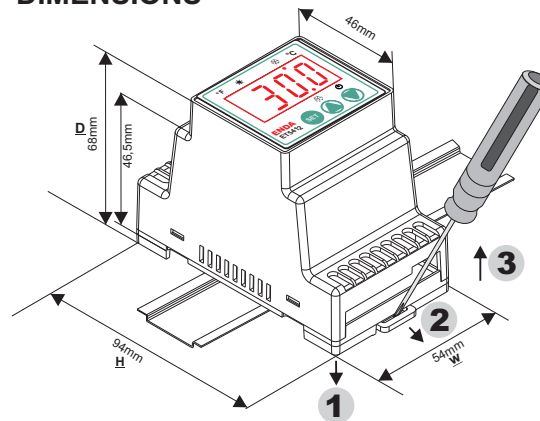

To mounting the device to the panel;
Push the device in direction **1**, the rails provide the key to keeping the rail.

To removing the device from rail;
Push the rail lock in direction **2** with a screwdriver and pull the device in direction **3**.



SISEL MÜHENDİSLİK ELEKTRONİK SAN. VE TİC. A.Ş.
Şerifali Mah. Barbaros Cad. No:18 Y.Dudullu 34775
ÜMRANIYE/İSTANBUL-TÜRKİYE
Tel : +90 216 499 46 64 Pbx. Fax : +90 216 365 74 01
url : www.enda.com.tr



ET5412-EN-02-220103

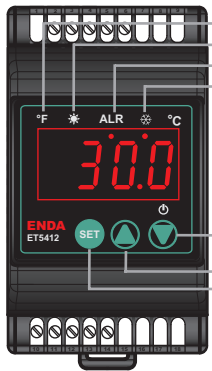

- °F FAHRENHEIT LED** : "F" Led lit if the temperature value in Fahrenheit unit.
- HEATING LED** : Heating LED lit during heating control if the output is active.
- ALARM LED** : Alarm LED lit if the alarm output is active.
- COOLING LED** : Cooling LED lit during cooling control if the output is active.
- ▼** While in "Programming Mode", provides the transition to the previous parameter. If parameter is being adjusted, it decreases parameter's value. Constantly holding this key, the parameter value rapidly decreases.
- ▲** While in "Programming Mode", provides the transition to the next parameter. If parameter is being adjusted, it increases parameter's value. Constantly holding this key, the parameter value rapidly increases.
- SET** Provides to display setpoint value, when pressed during "Running Mode". Provides to display parameter value, when pressed during "Programming Mode".

Running Mode

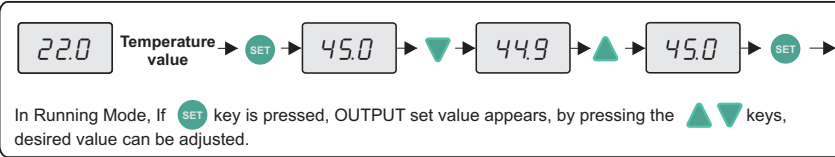

Programming Mode

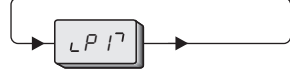

By holding down 3 seconds to **▲▼** keys together, "Programming Mode" is entered. If pressed the keys during the "Programming Mode", "Running Mode" is entered.

- uPL** Upper limit setpoint value
- LoL** Lower limit setpoint value
- HYS** Output hysteresis
- oFF** Output offset value
- CLYP** Control Type
(HE = Heating control
CO = Cooling control)
- Unit** Temperature Unit
- dPnt** Decimal Point Indication
(YES = Indicates as Decimal)
- ARSt** Alarm relay condition
no = output OFF
YES = output ON
- ALYP** Alarm type
AbS = Independent Alarm
rEF = Deviation Alarm

- ALHYS** Alarm Hysteresis
- ALoL** Alarm setpoint value Lower Limit
- ALuPL** Alarm setpoint value Upper Limit
- CLPPF** Output "ON" time duration in case of probe failure
- CLPPn** Output "OFF" time duration in case of probe failure

* **AdRS** Device address.

* **BAUD** Baudrate.

⚠ This feature available with Modbus devices only. Described at the end of the order code as with the "RS" addition.

Locking / Unlocking the Keys



To locking or unlocking the keypad, **SET** **▼** keys are pressed together for 2 seconds. **Loc** or **unL** message will appears for valid status.

Activating / Inactivating The Control Outputs



CLdS or **CLEnb** message will be displayed depends on the current status when pressed the **▼** key for 2 seconds in "Running Mode" and the control output status will be changed to active or inactive.

⚠ CLdS message appears periodically during "Running Mode" if the control output(s) inactive.

Error Messages

PFA No communication with thermostat sensor. (Sensor and/or cable broken or not connected)

PSC Thermostat probe or connection line short-circuited.

---- Temperature value is higher than the scale.

---- Temperature value is lower than the scale.

PARAMETER TABLE

LP 17	Menu Parameters	Min	Max.	Unit	Start Value
uPL	Upper limit for set value	LoL	1500	°C	150
LoL	Lower limit for set value	-600	uPL	°C	-60
HYS	Hysteresis output differential	0.1	200	°C	2
oFF	Output offset value	-200	200	°C	0
CLYP	Control type (HEAT = Heating control, COOL = Cooling control).	HEAT	COOL		HEAT
Unit	Temperature Unit	°C	°F	°C	
dPnt	Decimal point indication (YES = Indicates as Decimal. 22.3°C) (no = Indicates as Integer numeric (Non-Decimal) 22°C)	no	YES		no
CLPPn	ON Time for the output in case of Probe Failure.	0:00	99:00	min:sec	0:00
CLPPF	OFF Time for the output in case of Probe Failure.	0:00	99:00	min:sec	1:00
ALuPL	Upper limit for Alarm set value	ALoL	1500	°C	150
ALoL	Lower limit for Alarm set value	-600	ALuPL	°C	-60
ALHYS	Hysteresis Alarm differential	0.1	200	°C	2
ALYP	Alarm configuration if ALYP = AbS ; ALoL and ALuPL if ALYP = rEF ; LoL = SET - ALoL and ALuPL	AbS	rEF		AbS
ARSt	Alarm relay condition in case of probe failure	no	YES		no
*AdRS	Device address	1	247		1
*BAUD	Baudrate	oFF	19200		9600

ENDA ET5412 DIGITAL THERMOSTAT MODBUS PROTOCOL ADDRESS MAP

1.1 HOLDING REGISTERS

Holding Register Addresses		Data Type	Data Content	Parameter Name	Read/Write Permission	Status Value
Decimal	Hex					
0000d	0x0000	word	Set value	--	Readable/Writeable	-20
0001d	0x0001	word	Set point value upper limit	<i>uPL</i>	Readable/Writeable	150
0002d	0x0002	word	Alarm set point value upper limit	<i>RUPL</i>	Readable/Writeable	150
0003d	0x0003	word	Set point value lower limit	<i>LoL</i>	Readable/Writeable	-60
0004d	0x0004	word	Alarm set point value lower limit	<i>RLoL</i>	Readable/Writeable	-60
0005d	0x0005	word	Offset value	<i>oFF</i>	Readable/Writeable	0
0006d	0x0006	word	Output hysteresis	<i>HY5</i>	Readable/Writeable	2
0007d	0x0007	word	Alarm output hysteresis	<i>RHY5</i>	Readable/Writeable	2
0008d	0x0008	word	ON Time for the output in case of Probe Failure.	<i>CPPn</i>	Readable/Writeable	0:00(0 sec)
0009d	0x0009	word	OFF Time for the output in case of Probe Failure.	<i>CPPF</i>	Readable/Writeable	1:00(60 sec)
0010d	0x0010	word	Address value	<i>AdRS</i>	Readable/Writeable	1
0011d	0x0011	word	Baudrate (0=Off;1=1200;2=2400; 3=4800; 4=9600; 5=19200)	<i>bAud</i>	Readable/Writeable	9600

1.2 INPUT REGISTERS

Input Register Addresses		Data Type	Data Content	Parameter Name	Read/Write Permission
Decimal	Hex				
0000d	0x0000	word	Measured temperature value (°C / °F)	--	



Temperature value is read as "Input Register" parameter and this value with decimal part defined as a signed integer. (That is "23.5 °C" temperature will be at "235" value).

1.3 DISCRETE INPUTS

Discrete Input Addresses		Data Type	Data Content	Parameter Name	Read/Write Permission
Decimal	Hex				
0000d	0x00	Bit	Control output state (0 = OFF ; 1 = ON)	--	Read only
0001d	0x01	Bit	Alarm output state (0 = OFF ; 1 = ON)	--	Read only

1.4 COILS

Coil Addresses		Data Type	Data Content	Parameter Name	Read/Write Permission	Status Value
Decimal	Hex					
00d	0x00	Bit	Control type selection. OFF=Cooling control (<i>Co</i>) ON=Heating control (<i>HE</i>)	<i>CLYP</i>	Readable/Writeable	<i>Co</i>
01d	0x01	Bit	Temperature unit. OFF = °C , ON = °F	<i>Unit</i>	Readable/Writeable	<i>oC</i>
02d	0x02	Bit	Decimal point . OFF = <i>no</i> , ON = <i>YE5</i>	<i>dPnt</i>	Readable/Writeable	<i>no</i>
03d	0x03	Bit	Alarm configuration OFF = <i>Ab5</i> ON = <i>rEF</i>	<i>ALYP</i>	Readable/Writeable	<i>Ab5</i>
04d	0x04	Bit	Alarm relay condition in case of probe failure OFF = <i>no</i> ON = <i>YE5</i>	<i>AR5E</i>	Readable/Writeable	<i>no</i>

MODBUS COMMUNICATION PARAMETERS

<i>AdRS</i>	Device address for RS485 network connection. Adjustable between 1-247.	1	247	-	1
<i>bAud</i>	Baudrate (0=Off;1=1200;2=2400; 3=4800; 4=9600; 5=19200)	<i>oFF</i>	1920	-	9600

* MODBUS CONNECTION DIAGRAM

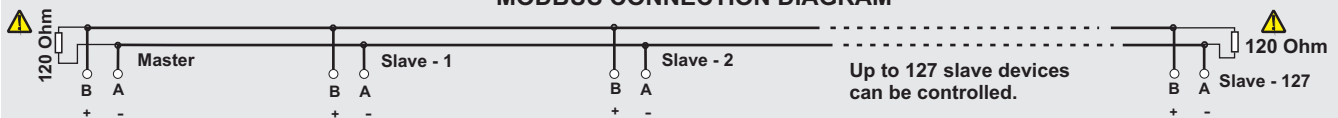

Termination should be accomplished by attaching 120 Ohm resistors to the start and at the end of the communication

* Applies to devices with Modbus function.