

# GMTCNT



## GSR-164R

## Mini PLC

## USER MANUAL

GMT ENDÜSTRİYEL ELEKTRONİK SAN. ve TİC. LTD. ŞTİ

# Let's start ...

## GSR-164R Mini PLC

---

GMTCNT

*This user manual contains the operating instructions for the Mini PLC product referenced in GSR-164R.*

*Please read and observe this user manual before operating your device! Please keep it for later use!*

*The user shall be liable for the damage caused by the failure to follow the instructions in the operating instructions and the accidents to be incurred by persons. In this case, the device is not covered by the warranty.*

## GSR-164R Mini PLC

### Foreword

*GMT Electronics is technology enterprise which is specialized R&D, manufacture, sales and service of industrial control, automation and process control products with our experiences over than 30 years.*

*GMTCNT is trade mark of GMT offers total solution with 5 main core products PLC, HMI, AC drive, Stepper, Servo system and industrial communication products.*

*GMT products are widely used in different sector. These are not only machine manufacturers such as food machinery, textile machinery, packaging, extruder, press, wood machinery also factory automation such as data acquisition and remote monitoring process.*

*Our products have proved themselves in many different places at the sector with their performance and quality.*

*GMT provides also cost performance products to customer, in order to make the customers more competitive in sector.*

*GMT will always continue to make investment to innovation and offer cost effective, easy and quick solutions.*

*Printed: March 2020 in Istanbul*



*We thank you for purchasing GMT CONTROL GSR-164R series Mini PLC and congratulate you on your decision.*

*In accordance with your wishes and desires, we develop the features of all our GMT CONTROL products and Mini PLC devices and we update them regularly.*

# Table of Contents

Foreword	0
<b>Part I INTRODUCTION TO USER MANUAL</b>	<b>7</b>
1 User manual guide .....	7
2 Valid range of this manual .....	7
3 Correct usage and safety requirements .....	7
<b>Part II GSR-164R Mini PLC</b>	<b>10</b>
1 Definition .....	10
2 Advantages .....	10
3 General Structure .....	11
<b>Part III SPECIFICATIONS</b>	<b>13</b>
1 General specifications .....	13
2 Technical specifications .....	13
3 Mechanical specifications .....	14
<b>Part IV MOUNTING, WIRING and INSTALLATION</b>	<b>16</b>
1 MOUNTING .....	16
Mounting considerations .....	16
DIN rail mounting .....	17
Removing from DIN rail .....	17
Panel mounting .....	18
Removing from panel .....	20
2 WIRING .....	20
Considerations for cabling .....	20
3 INSTALLATION .....	21
Installing device .....	21
GSR-164R Connection diagram .....	22
<b>Part V COM1 &amp; COM2 COMMUNICATION ADAPTERS</b>	<b>25</b>
1 GSR-COM1 & GSR-COM2 .....	25
2 GSR-COM1 Communication adapter .....	25
3 GSR-COM2 Communication adapter .....	25
4 How to use the GSR-COM1? .....	26
5 How to use the GSR-COM2? .....	26
<b>Part VI PROGRAMMING with GMTSuite</b>	<b>28</b>
1 How Do I Get GMTSuite? .....	28
<b>Part VII SYSTEM SETUP MENU</b>	<b>30</b>

<b>1 Sub-6 keypad usage .....</b>	<b>30</b>
<b>2 Top-6 keypad usage .....</b>	<b>30</b>
<b>3 System main menu .....</b>	<b>31</b>
<b>System menus .....</b>	<b>31</b>
<b>I/O (Int/Out) .....</b>	<b>32</b>
How do I access I/O Information?.....	32
<b>MEM (Memory) .....</b>	<b>32</b>
How do I load PRG, FRW, or BTL from USB?.....	33
How do I reset permanent memory?.....	33
<b>RTC (Clock) .....</b>	<b>34</b>
How do I Set RTC?.....	34
<b>SCR (LCD &amp; Keys) .....</b>	<b>35</b>
How do I Adjust the Display Brightness? .....	35
How do I test the 12-key to work properly?.....	36
<b>SYS (System) .....</b>	<b>36</b>
How Can I Get Status Information?.....	37
<b>PWD (Password) .....</b>	<b>37</b>
How do I create a new password?.....	38

**Part VIII MAINTENANCE & SUPPORT 40**

<b>1 Maintenance .....</b>	<b>40</b>
<b>2 Warranty Information .....</b>	<b>40</b>
<b>3 Support .....</b>	<b>41</b>
<b>4 User Review .....</b>	<b>41</b>

**PART**

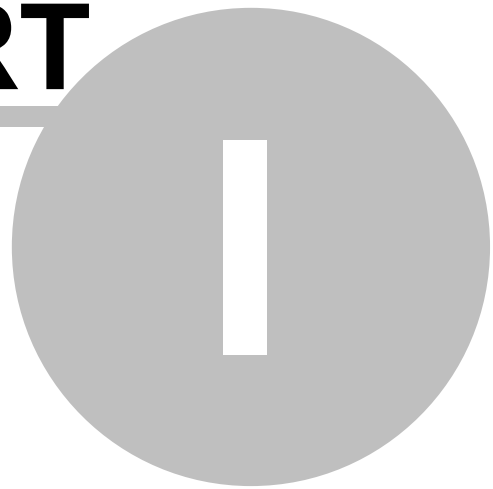

**GMT**CNT

**GSR-164R**

# 1 INTRODUCTION TO USER MANUAL

- When you purchase the Mini PLC GSR-164R, please check and confirm whether there is a missing, damaged condition, otherwise please contact your dealer.

## 1.1 User manual guide

- The **GSR-164R Mini PLC** manual is divided into 8 main chapters:
  - ❖ Introduction to User Manual,
  - ❖ Getting to Know Mini PLC GSR-164R with Display,
  - ❖ General, Technical and Mechanical Specifications,
  - ❖ Mounting, Wiring and Setup,
  - ❖ COM1 & COM2 Communication Adapters,
  - ❖ Programming with GMTSuite,
  - ❖ System Setup Menu,
  - ❖ Maintenance and Support,

## 1.2 Valid range of this manual

- The manual applies to devices of series **GSR**.

## 1.3 Correct usage and safety requirements

### Security Definition:

- This manual contains notices you have to observe in order to ensure your personal safety, as well as to prevent damage to property. The notices referring to your personal safety are highlighted in the manual by a safety alert symbol. In this manual, safety precautions are classified as follows:



**Danger**

Operations which are not performed according to requirements may cause serious equipment loss or personal injury.



**Caution**

Operations which are not performed according to requirements may cause medium hurt or light hurt or material loss.

During the installation, commissioning and maintenance of the system, please make sure to follow the instructions in the safety and precautions section of the manual.

- This user manual requires attention and care both for your personal safety and for the protection of this product and its equipment. Only qualified personnel should be allowed to install the device. Qualified personnel are defined as persons authorized to perform commissioning, wiring, grounding according to current regulations and safety standards.
- Always cut off all energy when connecting or disconnecting the device to DIN rail or panel. Take precautions to prevent unwanted relay opening. Make connect the required ground and short circuit connections.

- Automation and control devices must be mounted in such a way that they are protected against the risk of unwanted operation. All connections of the control system must comply with the applicable safety standards.
- Fluctuations or variations in the supply voltage must not exceed the threshold values specified in the technical specifications, otherwise it may cause malfunctions and potentially hazardous situations
- When an application has been interrupted due to interruptions in the supply voltage, take all necessary measures to ensure that the application continues to function correctly and that no hazardous situation occurs.
- Please do not interfere to the device during the technical problem and contact with the technical service as soon as possible.
- This device and its packing is not litter and may not be disposed of with domestic waste. Please return this device to an appropriate recycling point (Contact a certified electronic waste disposal center) at the end of its service life.

In case the above-mentioned warnings are not taken into account, our company or the authorized dealer cannot be held responsible for any negative consequences.



**PART**

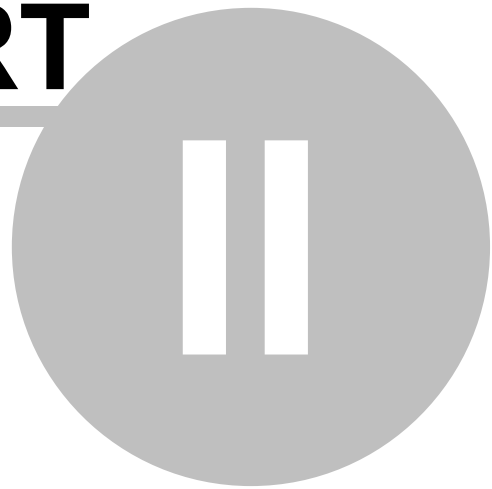

**GMT**CNT

**GSR-164R**

## 2 GSR-164R Mini PLC

### 2.1 Definition

- The **GSR-164R** is a mini PLC device with electronic display that controls a system with inputs-outputs and provides general control with its timing, counting, storage and arithmetic operation functions. The display of the device provides a significant advantage in terms of ease of usage. The upper and lower router keypad on the device provides easy access to system setting units and easy usage of the system. After you create your program in Ladder language, it is enough to connect your computer to operate your device.
- **GSR-164R Mini PLC** is flexible, economical and user-friendly.

### 2.2 Advantages

- Display and keypad provide ease of usage.
- The device dimensions are designed as compact as possible, considering the limited areas, it can be easily assembled to the small cabinet and panels where the control system is located.
- The compact design of the device significantly reduces the cost of wiring for systems.
- Easy setup and a ready-to-use system enabled it to reach many more establishment in the industrial area.
- The device has 6 digital / analog inputs, it does not require additional analog modules.
- Advanced **GMTSuite** editor is used. Thus, ladder logic, **off-line** simulation, **on-line** simulation, graphic editor and so on many features can be used.
- Easy and practical automation systems can be set up, due to the planned structure without the need for deep programming knowledge.

## 2.3 General Structure

- In **figure 1**, the general structure of the **GSR-164R Mini PLC** is shown in 7 main sections.

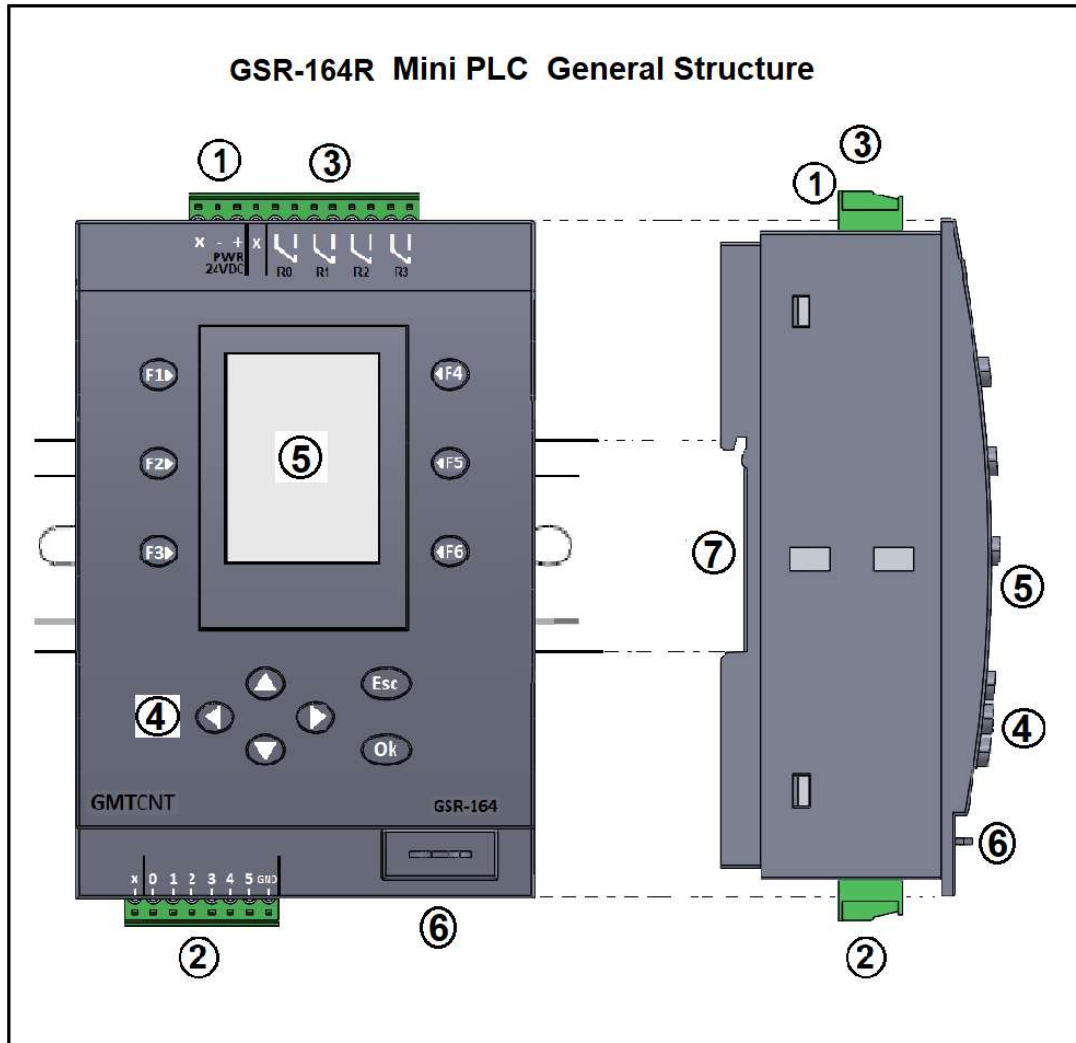
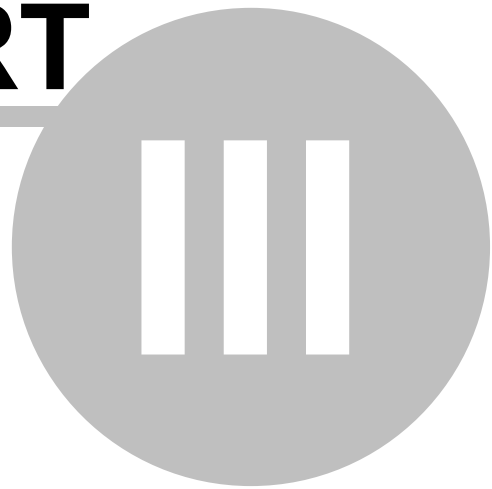

Figure - 1 General Structure

- ① Power Supply
- ② Digital / Analog Inputs
- ③ Outputs
- ④ Control panel keypad (12-key)
- ⑤ TFT LCD Screen
- ⑥ Programming socket housing
- ⑦ DIN rail mounting area

**PART**



**GMT**CNT

**GSR-164R**

## 3 SPECIFICATIONS

### 3.1 General specifications

- **GSR-164R Mini PLC** is designed for automatic control applications in industrial environments.
  1. **24 VDC Power Supply**,
  2. **6 channel Digital (PNP) / Analog Inputs (0-10V) (12 bit resolution)**,
  3. **4 channel Relay Outputs (5A @ 220 VAC)**,
  4. **1.8 inch 128 (RGB) x 160 TFT LCD screen**,
  5. For user interface inputs on the front of the programmable device; 6 of them are programmable, total 12-key keypad.
  6. Easy testability of the operation of the 12-key keypad.
  7. Ladder Logic **GMTSuite** editor; (programming, simulation, download) The **GMTSuite** editor software can be downloaded for free from <http://www.gmtcontrol.com/tr/yuklemeler/yazilimlar.html>,
  8. Provides online input-output information via LCD screen and it provides ease of operation and maintenance.
  9. **Real time clock (RTC)** is available.
  10. Reverse polarity protection is available.
  11. Short circuit protection and overload protection is available.
  12. Analog input / output values can be monitored on the device screen.
  13. Color display brightness adjustment is available. It can be set from 100% to 10% gradually.
  14. Due to its compact size, it can be easily placed in any limited space ( 83 mm x 113,7 mm x 47 mm).
  15. Suitable for permanent DIN rail mounting and panel type mounting.
  16. Turkish / English language option is available.

### 3.2 Technical specifications

- Observe the following voltage tolerances, mains frequencies and power consumption details.
  1. **Power Supply: 24 VDC ( % ±10 tolerans)**,
  2. **6 channel digital (PNP) / analog inputs (0-10V)**,
  3. **4 channel relay outputs (5A @ 220 VAC)**,
  4. Maximum counting speed at digital inputs **2 kHz (50% duty cycle)**,
  5. Maximum **20 kHz** program cycle speed,
  6. **48 kB** program memory,
  7. Decimal transaction support,
  8. Ladder Programming,
  9. **Analog Input:** Measuring range 0 to 10 VDC (12-bit resolution), Distortion voltage max. 16VDC,
  10. **Analog Input Sampling Periods:** 100 ms,
  11. **Digital Outputs (Relay):** Relay, maks. 250VAC, 5A, Resistive load,
  12. **Power Consumption:** Maximum 3W (Peak current value 0.8 A while power is on),
  13. **Operating Temperature:** 0°C .. 50°C,
  14. **Storage Temperature:** -10°C .. 60°C (without freezing),
  15. **Humidity:** %80 up to 30°C, 50% at 50°C after linear decrease,

- 16. EMC : Electromagnetic Compatibility** EN 61000-4-2, EN 61000-4-4, EN 61000-4-5,  
**EN 61000-4-2:** Testing and measurement techniques, Electrostatic Discharge immunity test (ESD)  $\pm 2$ ,  $\pm 4$ ,  $\pm 8$  kV Air discharge;  $\pm 2$ ,  $\pm 4$  kV Contact discharge.  
**EN 61000-4-4:** Testing and measurement techniques, Electrical Fast Transient (EFT) / burst immunity test, Power line:  $\pm 4$  kV, Signal line:  $\pm 4$  kV (5KHz, 20KHz and 100KHz).  
**EN 61000-4-6:** Testing and measurement techniques, Surge immunity test (SUG); up to  $\pm 500$  V.
- 17. Relay Load Life (ambient temperature: 23°C)**  
**Mechanical:** 5,000,000 operations min.  
**Electrical (resistive load):** 100,000 operations at 250 VAC, 5 A  
 200,000 operations at 30 VDC, 3 A  
 (with a rated load at 1,800 operations / hour)

### 3.3 Mechanical specifications

- 1 **Dimensions (width, length, GSR-164R ; 83 x 113,7 x 47 mm, height);**
- 2 **Mounting Type;** **GSR-COM1;** 22 x 48 x 14 mm,  
**GSR-COM2;** 22 x 48 x 14 mm,  
35 mm DIN rail mounting  
Panel mounting (Open-profile of **panel** should be width;80 mm & length;111 mm)  
Profile of **device** is width;79 mm & length;110 mm.
- 3 **Weight;** **GSR-164R;**213 gr **GSR-COM1;**5 gr **GSR-COM2;**5 gr
- 4 **Display;** Color LCD screen 1.8 inch,  
Mini TFT LCD 128 (RGB) x 160,  
Display LCD outline: 34 x 47 x 2.4 mm,  
Display active area: 28,03 x 35,04 mm,  
Display resolution: 128 (RGB) x 160.
- 5 **Terminal Crimping Torque;** Max. 0.56 N.m

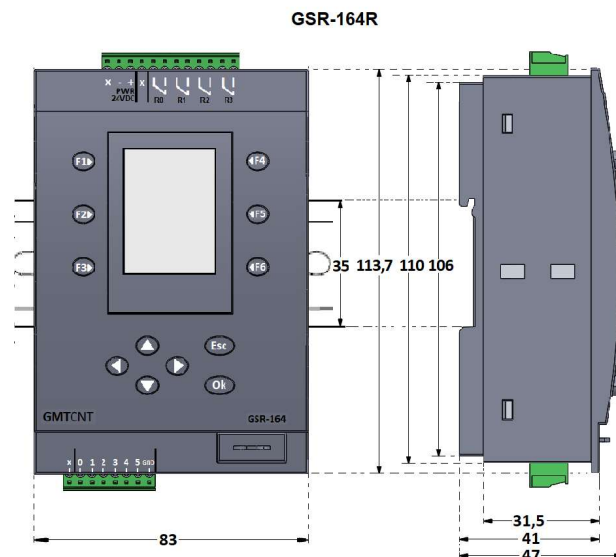

Şekil - 2 Mechanical dimensions

**PART**

**IV**

**GMT**CNT

**GSR-164R**

## 4 MOUNTING, WIRING and INSTALLATION

### 4.1 MOUNTING

- During mounting and removing ;

**Danger**

Place the device on a non-flammable surface such as metal and keep the device away from flammable materials; otherwise it may cause fire.

Do not leave the mounting screws of the appliance loose.

**Caution**

Do not drop cable glands or screws into the device from the upper and lower terminal entries of the device; otherwise it may damage the device.

Mounting the device in a place where there is no direct sunlight or vibration.

When mounting more than two devices into a cabinet, pay attention to the mounting distances for heat circulation.

- **GMTCNT GSR-164R** Mini PLC is suitable for mounting to DIN rail and also for panel mounting. The device can be mounted on rail according to DIN EN 50022 width 35 mm. The width of the device is 83 mm. This section describes how to mounting / removing the device.

#### 4.1.1 Mounting considerations

- Always power off when mounting and removing the device. Take precautions to prevent unwanted relay opening. Make the necessary ground and short circuit connections.
- Protect the device from rain and direct sunlight by mounting the appliance in the electrical cabin.
- Protect from combustible and flammable materials.
- Mount the device to the panel inside which is the panel with air circulation in such a way that air ducts are not blocked.
- Mount the device in a protected manner against adverse environmental conditions such as humidity, vibration, pollution and very high/low temperature.
- Do not operate the device other than those specified and environmental conditions in section 3.



### 4.1.2 DIN rail mounting

- In order to mount the device to DIN rail as in **figure 3**;

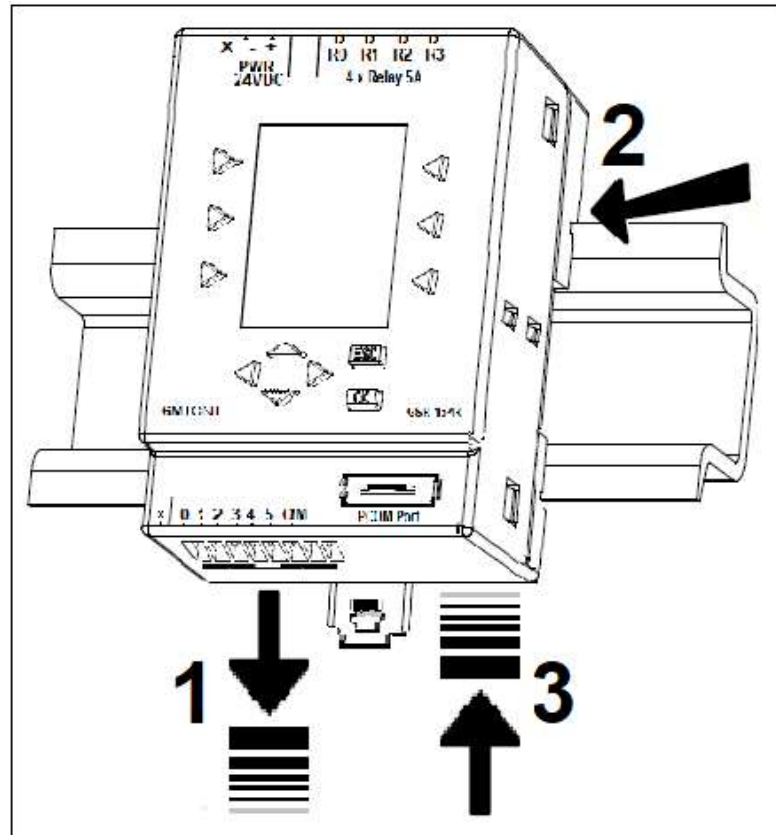

Figure - 3 GSR-164R DIN rail mounting

- shown by number **1**; the fixed **rail-clip** is pulled downwards gradually and retained in the last step. Thus, the area where the DIN rail will sit is opened.
- shown by number **2**; slot on the back of the device is inserted into the DIN rail. The device is gripped by hand and pushed on the DIN rail.
- shown by number **3**; the fixed **rail-clip** is pushed upwards gradually and locked to the DIN rail.

### 4.1.3 Removing from DIN rail

- Always switch off power before removing the device.
- The fixed rail-clip shown by number **1** is pulled downwards gradually so that the locked rail-clip is released.
- The released device shown by number **2** is taken off the DIN rail by lifted upwards.

### 4.1.4 Panel mounting

- During the panel mounting firstly it should be paid attention to the cross section of the panel-window. In order for the device to fit into the panel as shown in **figure 4**, panel inner dimension **80 mm x 111 mm**. The panel-based cross-section of the device is **79 mm x 110 mm**, as shown in **figure 4**.

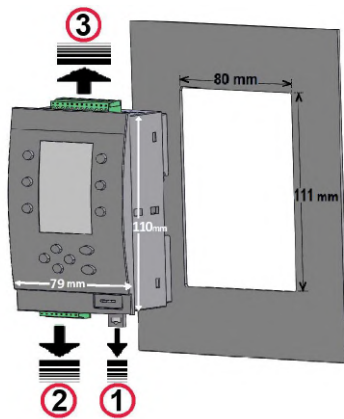

Figure - 4 GSR-164R panel mounting

- The rail-clip (factory-mounted) which is shown number **1** in **figures 4 & 5** is remove from the back-side of the device.

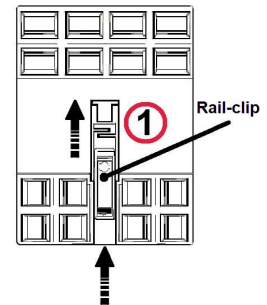

Figure - 5 Back-side / Rail-clip

- The green terminals (factory-mounted) 8 and 12 input / output which is shown numbers **2 & 3** in **figure 4** is remove from the upper and lower surfaces of the device.
- The device place vertically in the panel as shown below in **figure 6**.

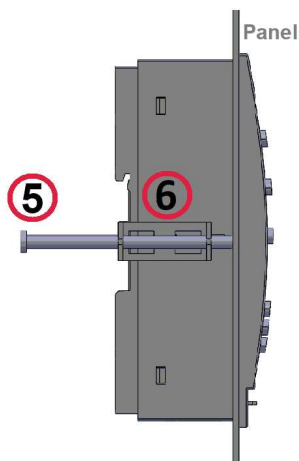

Figure - 6 Profile of the device

- **Metal-fixing-apparatus (with double-nail) (6)** mount in the holes of the device shown with number **4** in **figure 7**.

- These two **metal-fixing-apparatus** must firmly seated.

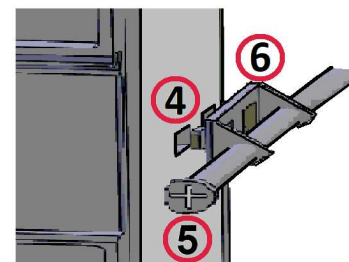

Figure - 7 Metal-fixing-apparatus

- Using a screwdriver, fix **two screws (5)** (M4 metal YSB 60 mm) through the double hole on the **metal-fixing-apparatus (6)** shown in **figure 6, 7, 8 & 9**.

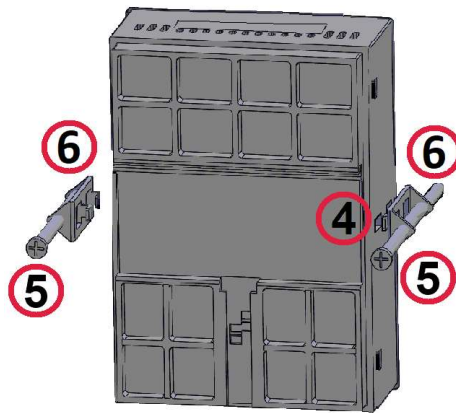

Figure - 8 Fixing the device to the panel

- Metal-fixing-apparatus (with double-nail) (x2)** and **M4 YSB 60 mm screw (x2)** shown in **figures 8 & 9**.

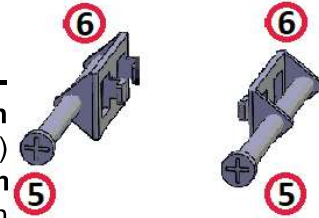
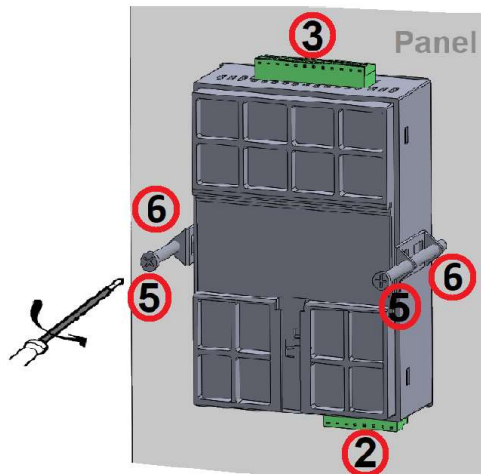

Figure - 9  
Metal-apparatus (double-nail) (6)  
& screw (5) M4 YSB 60mm

- The device is locked to the panel as shown in **figure 10**. After mounting the panel shown below is the front-face and back-face of the device. Finally, place the 8 and 12 input / output (**2 & 3**) terminal blocks. Once the device is power on, the PLC program is loaded and operated.



back side of the device



front of the device from the panel

Figure - 10 Front-face & back-face of the device

- ① number: Rail-clip
- ② number: Input terminals 8-pin 3.5mm
- ③ number: Output terminals 12-pin 3.5mm
- ④ number: Metal-fixing-apparatus-holes
- ⑤ number: 60mm M4 metal YSB screw
- ⑥ number: Metal-fixing-apparatus(double-nail)

### 4.1.5 Removing from panel

- Always switch off power before remove device from the panel.
- Remove the screws (**M4 metal YSB 60 mm x2**) by turning them with a screwdriver shown in number ⑤.
- Pull the **metal-fixing-apparatus** (double-nail) out from holes shown in number ⑥. Swing the device off the panel.

## 4.2 WIRING

- During the connection of cables;



### Dange

Only skilled personnel should be allowed to start and operate this device. Qualified personnel in the sense of the information on safety technology in this manual are persons who are authorized to commission, to ground and to tag circuits, equipment and systems in accordance with safety regulations and standards.

Before installation and any technical work, disconnect the power supply and mains connections otherwise there may be a risk of electric shock. Make sure the ground connection is connected correctly otherwise there may be a risk of electric shock.



### Caution

Pay attention to the wiring warnings and connect the cables correctly otherwise doing so may damage the device.

Ensure EMC and safety standards are appropriate. Follow the instructions in the manual during the wiring. Otherwise doing so may cause an injury or risk of electric shock.

Always use twisted and shielded cables for analog signals, and keep these as short as possible the cable must be grounded properly.

### 4.2.1 Considerations for cabling

- Please use cable cross-section according to the current. Cable connections can be made with cables with a maximum of 1.5 mm<sup>2</sup>. Cable cross-sectional range that can enter the device terminals; 0,5 mm<sup>2</sup> (20 AWG) ~ 1,5 mm<sup>2</sup> (16 AWG). Table-1 lists the minimum possible cross-section values.

Cable cross section	Power Supply 24VDC / External	Min :	0.37mm <sup>2</sup> (AWG 21)
	Input / Output	Digital Input	0.29mm <sup>2</sup> (AWG 22) – 0.59mm <sup>2</sup> (AWG 20)
		Digital Output	0.033mm <sup>2</sup> (AWG 32) – 0.066mm <sup>2</sup> (AWG 29)
		Analog Input	0.0035mm <sup>2</sup> (AWG 37)
		Analog Output	0.0035mm <sup>2</sup> (AWG 37)

Table - 1 Cable cross section

- The terminals must not be overtightened. Maximum torque for screwing; 0.56 Nm. The maximum torque that can be applied for input / output and supply voltage is indicated in Table-2.

Tightening torque of screw terminals	Power Supply 24VDC / External	0.45 Nm (4lb-in)
	Input / Output	0.56 Nm (5lb-in)

Table - 2 Torque for screwing

- Keep the cabling as short as possible. If longer cables are necessary, you should use shielded versions. You should always route your cables in pairs.
- Always keep separate: The AC wiring, High-voltage DC circuits with high-frequency switching cycles and Low-voltage signal wiring.
- Ensure that the cables have sufficient mechanical strength.
- Provide a suitable lightning surge arrester for cables installed in relevant areas of hazard.
- Keep device, signal cables and communication cables away from circuit breakers, power cables and devices/cables emitting electrical noise. Use shielded and twisted signal and communication cables and connect shield to earth ground on device side.

## 4.3 INSTALLATION

### 4.3.1 Installing device

- During the setup of the device;



#### Danger

Do not use devices that are flooded, damaged, or missing parts otherwise, the device may be at risk of damage. Use insulation otherwise there may be a risk of electric shock.



#### Caution

During shipping be careful not to damage the device. Do not use the controller with damaged or missing parts, otherwise there is a risk of injury. Do not touch any electronic parts and components, otherwise it may cause static electricity.

- Please read the user manual of the device thoroughly before using and setup. Observe the notes and warning in this manual. Always ensure that the wiring and setup of device is compliant with current rules and mandatory standards. Also, conform with all national and regional regulations when you install and operate the devices. For information on standards and regulations that apply to your specific case, contact your local authorities.

### 4.3.2 GSR-164R Connection diagram

- Digital inputs or analog inputs must be connected as described below in the connection diagram shown in **figure 11**. For inputs a 8 pin (3.5mm/8P) terminal and for outputs a 12 pin (3.5mm/12P) terminal must be use.

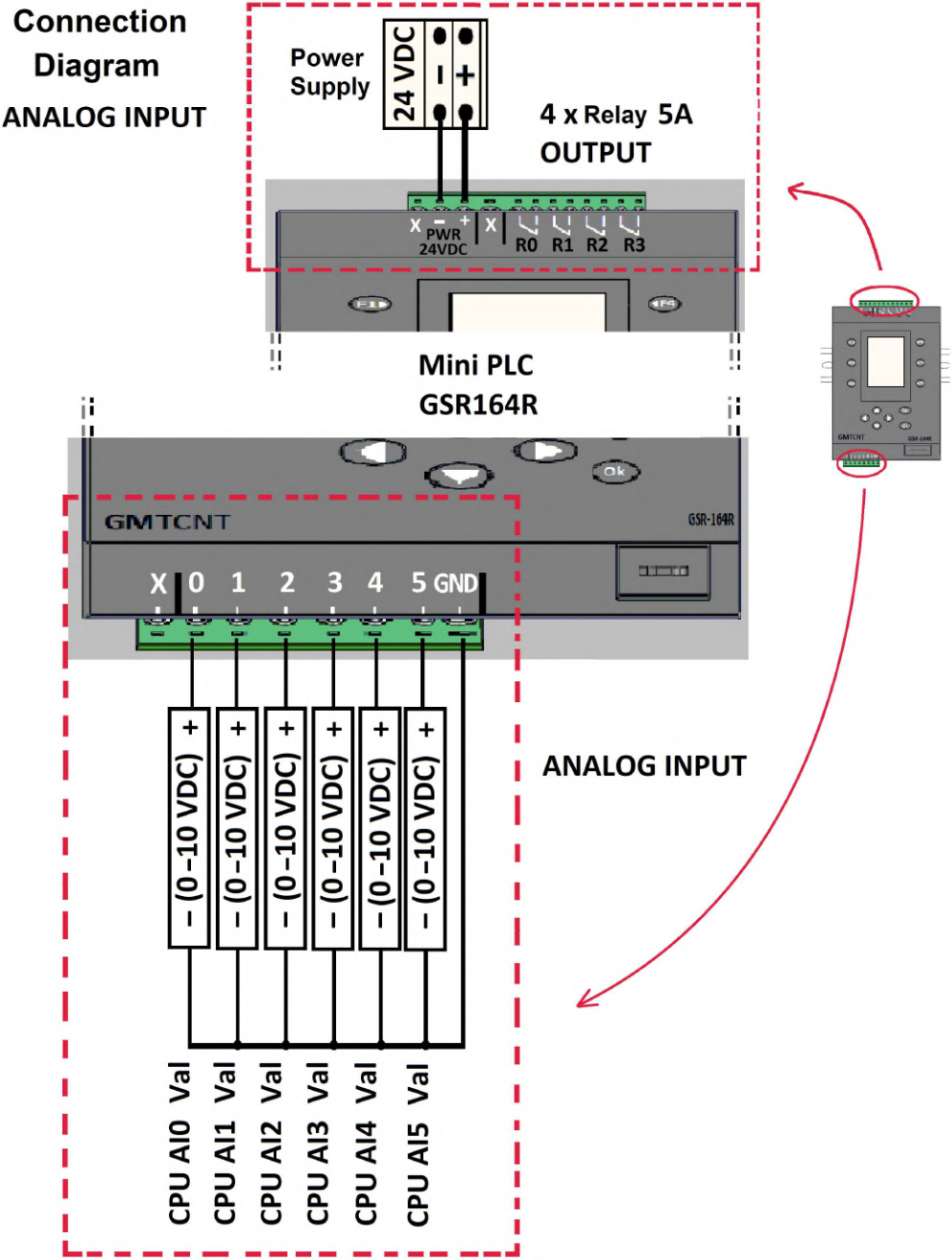

Figure - 11a Analog input connection diagram

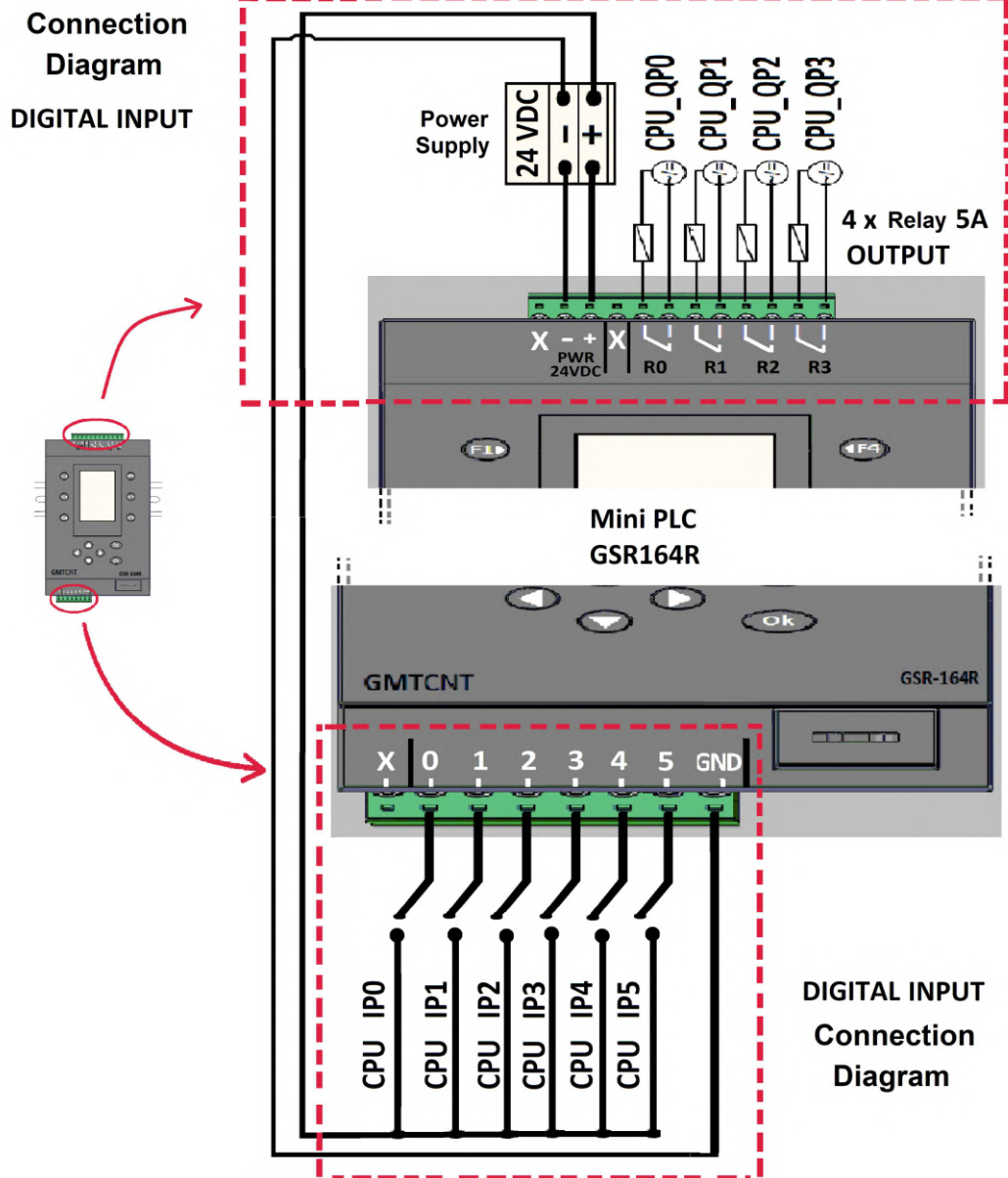

Figure - 11b Digital input connection diagram

- Note: Analog and digital connections can be used together and in any order.

**PART**



**GMT**CNT

**GSR-164R**



## 5 COM1 & COM2 COMMUNICATION ADAPTERS

### 5.1 GSR-COM1 & GSR-COM2

- The **GSR-164R** Mini PLC can be programmed in two different ways;

1- Using the communication adapter **GSR-COM1**; the device is connected to the computer via **USB 2.0 A Male - Mini B** cable, and then the program is loaded from the **GMTSuite** editor.

2- Using the communication adapter **GSR-COM2**; the PLC program is loaded to the device with the **USB flash memory**.

### 5.2 GSR-COM1 Communication adapter

- The **GSR-COM1** is a program installation communication adapter shown in **figure 12**, which provides a **mini USB** connection with the **GSR-164R Mini PLC**. Allows you to connect to your PC with the **USB 2.0 A-Male - Mini-B cable**.



Figure - 12 GSR-COM1 Communication adapter

### 5.3 GSR-COM2 Communication adapter

- The **GSR-COM2** is a program upload adapter that provides **USB** connection with the **GSR-164R Mini PLC** as shown in **figure 13**. The programmable **GSR-164R Mini PLC** can be easily loaded with **USB flash memory**. The **USB data format** should be **Fat32**.



Figure - 13 GSR- COM2 Communication adapter

## 5.4 How to use the GSR-COM1?

- The **USB-port-cover** on the communication **PCOM-Port** of the device is removed by holding the cover or using a screwdriver.

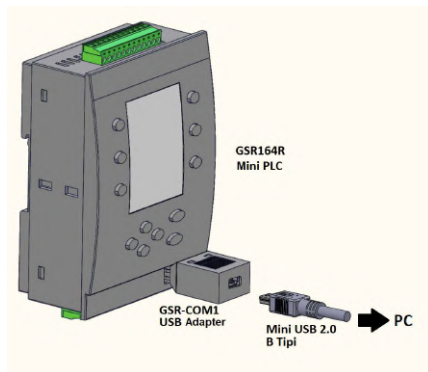

Figure - 14 GSR-COM1

- As shown in **figure 14**, **GSR-COM1** communication adapter is inserted into the **PCOM Port slot**.
- Insert the **mini-B** end of the "**USB 2.0 A-Male to Mini-B**" cable to the mini USB port of the GSR-COM1 USB communication adapter.
- The other **USB 2.0 A-Male** end of the cable is connected to the computer.
- After switch on power the device, enter the web address [www.gmtcontrol.com](http://www.gmtcontrol.com) via internet.
- Download the PLC Editor program (**Yuklemeler > Yazılımlar > GMTSuite > PLC Editor**).
- Run the PLC program prepared in ladder language and then desired application is implemented.

## 5.5 How to use the GSR-COM2?

- The **USB-port-cover** on the communication **PCOM-Port** of the device is removed by holding the cover or using a screwdriver.

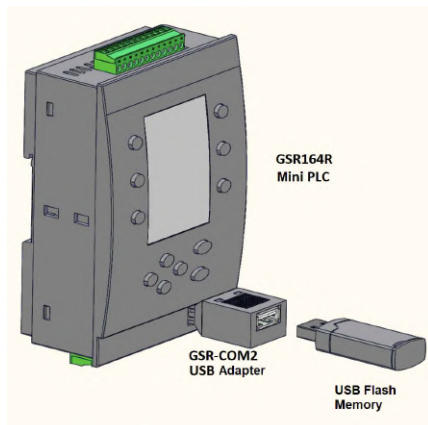

Figure - 15 GSR-COM2

- As shown in **figure 15**, insert the **GSR-COM2** communication adapter into the **PCOM Port slot**.
- After switch on power the device, insert the program loaded **USB flash memory** into the **USB port** of the **GSR-COM2**.
- Previously in the GMTSuite editor, open the relevant project and prepare it in a USB flash memory.
- Enter the main menu; "**F2▶**" **MEM** (Memory) > "**F1▶**" **DWN** (USB>PLC) push the buttons;
- "**USB & FILES**" should be "**USB:ok & FILES:ok**" on the screen and then press the "**F1▶**" **PRG** (Program) key and save the relevant project.

**PART**

**VI**

**GMT**CNT

**GSR-164R**

## 6 PROGRAMMING with GMTSuite

### 6.1 How Do I Get GMTSuite?

- Enter the company's web address **www.gmtcontrol.com** from your computer.
- Download updated versions ladder logic **GMTSuite PLC Editor** software **free of charge** from the Internet address of our company (<http://www.gmtcontrol.com/tr/yuklemeler/yazilimlar.html>).
- After completing the installation and wiring described in chapter 4, switch on power the device.
- Finally you can implement the PLC program you have prepared with the help of communication adapters (COM1 and COM2) provided by our company.

**PART**



**GMT**CNT

**GSR-164R**

## 7 SYSTEM SETUP MENU

- The device has a total of 12 keys for 6 programming purposes. The following describes how and for what purposes this 12-key keypad is used.

### 7.1 Sub-6 keypad usage

- The sub-6 keypad shown in **figure 16** usually used for general routing and transition.

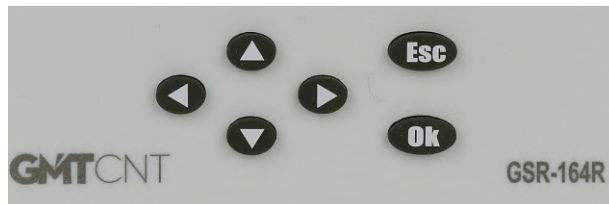







Figure - 16 Sub-6 keypad

- The description of each key of the sub-6 keypad is shown below;

	it is a general selection key and a confirm key.
	It is an exit key which is used for output without numerical change recording.
	It is use to pass from one variable to the next variable at the sub-6 keypad menu.
	It is use to return to the previous variable at the sub-6 keypad menu.
	It is use to increase the parameter value at the sub-6 keypad menu.
	it is use to decrease the parameter value at the sub-6 keypad menu.

### 7.2 Top-6 keypad usage

- **Figure 17** shows the top-6 keypad. “F1▶”, “F2▶”, “F3▶”, “◀F4”, “◀F5” and “◀F6” keys are used to pass from one menu to another menu and also they are used to assign tasks within a program. The following explains how to go to the system main menu and other menus.



Figure - 17 Top-6 keypad

## 7.3 System main menu

- After setup of the device and the cable connection is completed and also mounting, the first power is supplied to the device.
- Press and hold on about 3 seconds the **Ok** key on the device. “**GSR Settings Password 00000**” appears on the color display.
- To enter the desired password, press the **Ok** key again to activate the 5 digit “**Password**” field.
- The default “00001” as “**Password**” is entered by pressing the **▲** key once.
- Finally confirm with the **Ok** key and enter the **main menu**.

### 7.3.1 System menus

- Shown in **figure 18** color screen is the main menu of the system; by turns;

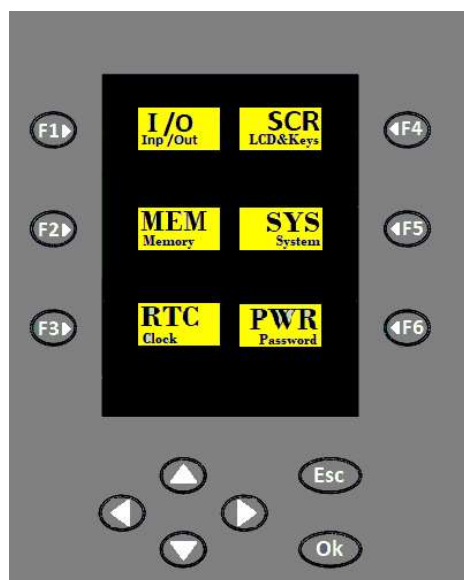

Figure - 18 System main menu

I/O (Inp/Out.) at the “**F1▶**”,  
MEM (Memory) at the “**F2▶**”,  
RTC (Clock) at the “**F3▶**”,  
SCR (LCD & Keys) at the “**◀F4**”,  
SYS (System) at the “**◀F5**”,  
PWR (Password) at the “**◀F6**”,

- To exit the system main menu, simply press the **Esc** key on the device.

### 7.3.2 I/O (Int/Out)

- At the system main menu, when pressing the “F1▶” key (**I/O (Inp/Out)**);

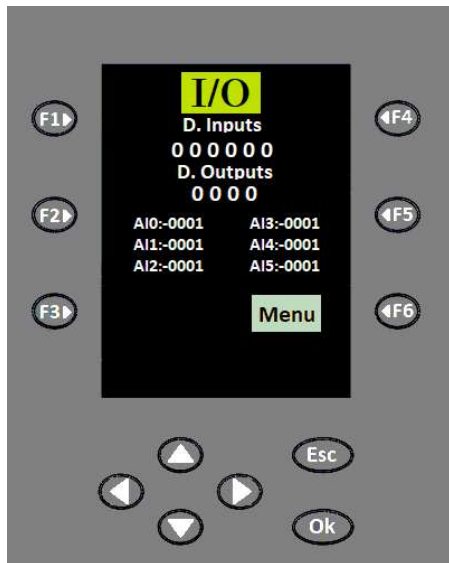

Figure - 19 I/O (Int/Out.)

- As shown in **figure 19**, **6 channel digital input**, **4 channel digital output** and **6 channel analog input** (AI0, AI1, AI2, AI3, AI4 and AI5) are read from the color LCD display.
- Pressing once is enough to the “◀F6” key which is beside the “Menu” to return to the **system main menu**.

#### 7.3.2.1 How do I access I/O Information?

- Press the “F1▶” key which is beside the "**I/O (Int / Out)**" on the system main menu screen.
- Follow live working system of digital (**6 channel inputs** and **4 channel outputs**) values or analog (**6 channel inputs**) values on TFT LCD color display.

### 7.3.3 MEM (Memory)

- At the system main menu, when pressing the “F2▶” key (**MEM (Memory)**);

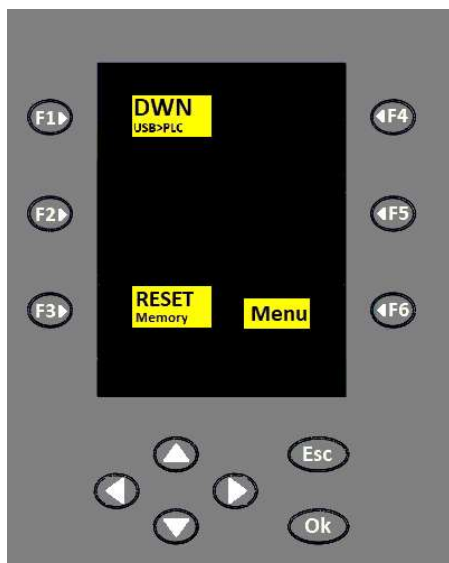

Figurel - 20 MEM (Memory)

- As shown in **figure 20**, "**DWN**" (**USB>PLC**) which is beside the “F1▶” key and "**RESET**" (**Memory**) which is beside the “F3▶” key are read from the color LCD display.
- The program, firmware and bootloader is downloaded from USB easily by pressing the “F1▶” (“DWN” > “PRG” or “FRM” or “BTL”) key once.
- The memory resetting easily by pressing the “F3▶” (“RESET” **Memory**) key once.
- Pressing once is enough to the “◀F6” key which is beside the “Menu” to return to the **system main menu**.



### 7.3.3.1 How do I load PRG, FRW, or BTL from USB?

- As shown in **figure 21**, press the “**F2**▶” key which is beside the **MEM (Memory)** on the system main menu screen to enter the **DWN (Download)** menu screen. From here, press the “**F1**▶” key at **DWN (USB> PLC)** to enter the program loading screen. Using the **GSR-COM2** communication adapter, the device is loaded the existing PLC program (**PRG**), firmware (**FRW**) or bootloader (**BTL**) by the **USB flash memory**. When the download processing is completed “**USB: xx!**” and “**FILES: xx!**” become to “**USB: ok**” and “**FILES: ok**”.

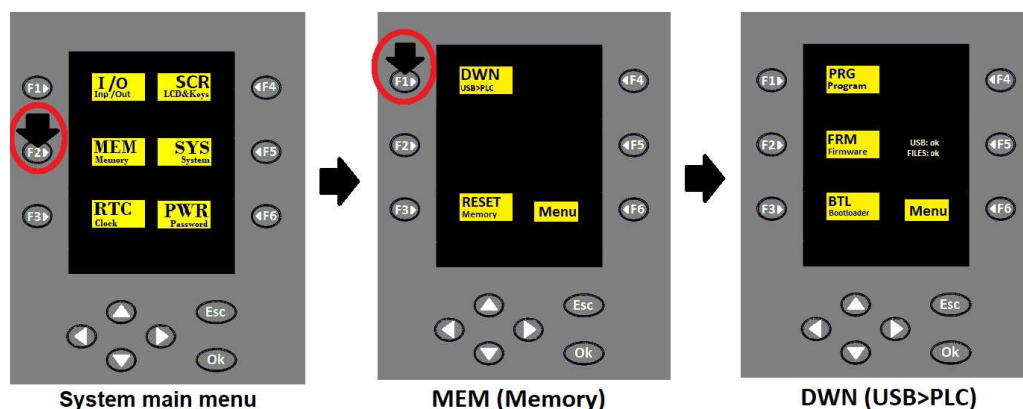

Figure - 21 "Download" screen

- Pressing twice is enough to the “◀**F6**” key which is beside the “**Menu**” to return to the system main menu.

### 7.3.3.2 How do I reset permanent memory?

- As shown in **figure 22**, press the “**F2**▶” key which is beside the **MEM (Memory)** on the system main menu screen to enter the **MEM** menu screen. From here, press the “**F3**▶” key at **RESET (Memory)** to reset all values in permanent memory.

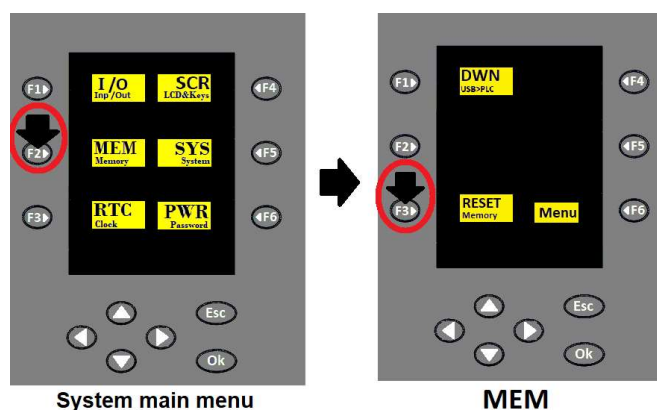

Figure - 22 Reset permanent memory

- Pressing once is enough to the “◀**F6**” key which is beside the “**Menu**” to return to the system main menu.

### 7.3.4 RTC (Clock)

- At the system main menu, when pressing the “F3▶” key (**RTC (Clock)**);

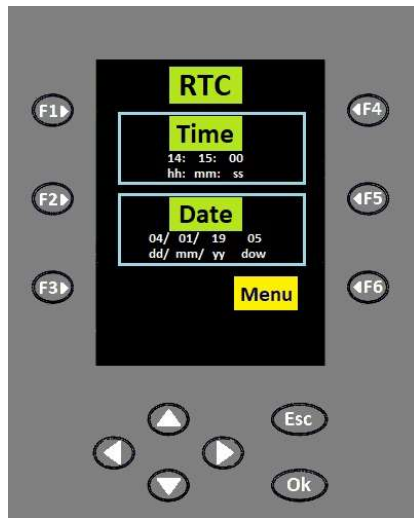

Figure 23 RTC (Clock)

- As shown in **figure 23**, **RTC** (Real Time Clock), **Time** (hh:hour / mm:minute / ss:second) and **Date** (dd:day / mm:month / yy:year / dow:day of week) are read from the color LCD display.
- Pressing once is enough to the “◀F6” key which is beside the “Menu” to return to the **system main menu**.

#### 7.3.4.1 How do I Set RTC?

- As shown in **figure 24**, press “F3▶” the key which is beside the **RTC (Clock)** on the **system main menu** screen to enter the **RTC** menu screen. **RTC** (Real Time Clock), **time** (hh:hour / mm:minute / ss:second) and **date** (dd:day / mm:month / yy:year / dow:day of week) parameter values are set using the routing keys (sub-6 keypad).

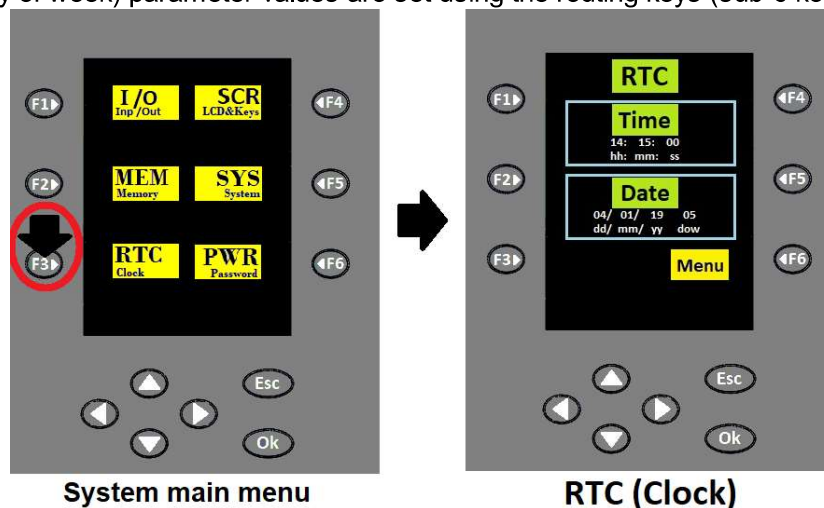

Figure 24 RTC setup

- The parameters that you want to set are activated by the **Ok** key. Each parameter that is activated is assigned the current values with the **▲** (up) or **▼** (down) keys. The assigned values are confirmed again by pressing the **Ok** key. For the transition to other parameters. The **◀** (left) or **▶** (right) routing keys are used.
- Pressing once is enough to the “◀F6” key which is beside the “Menu” to return to the **system main menu**.

### 7.3.5 SCR (LCD & Keys)

- At the system main menu, when pressing the “◀F4” key (**SCR (LCD & Keys)**);

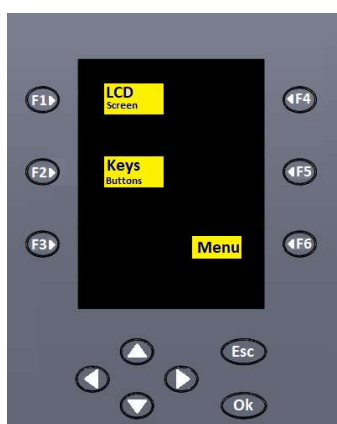

Figure - 25 SCR (LCD & Keys)

- As shown in **figure 25**, "LCD (Screen)" which is beside the "F1▶" key and "Keys (Buttons)" which is beside the "F2▶" key are read from the color LCD display.
- Press the "F1▶" key which is beside the "LCD" (Screen)' to adjust the screen brightness.
- Press the "F2▶" key which is beside the "Keys" (Buttons)' to test working properly of the 12 keys.
- Pressing once is enough to the "◀F6" key which is beside the "Menu" to return to the **system main menu**.

#### 7.3.5.1 How do I Adjust the Display Brightness?

- As shown in **figure 26**, press the "◀F4" key which is beside the **SCR (LCD & Keys)** on the **system main menu** screen to enter the **SCR** menu screen. From here, press the "F1▶" key on the **LCD (Screen)** to adjust and test gradually the brightness of the TFT LCD color display.

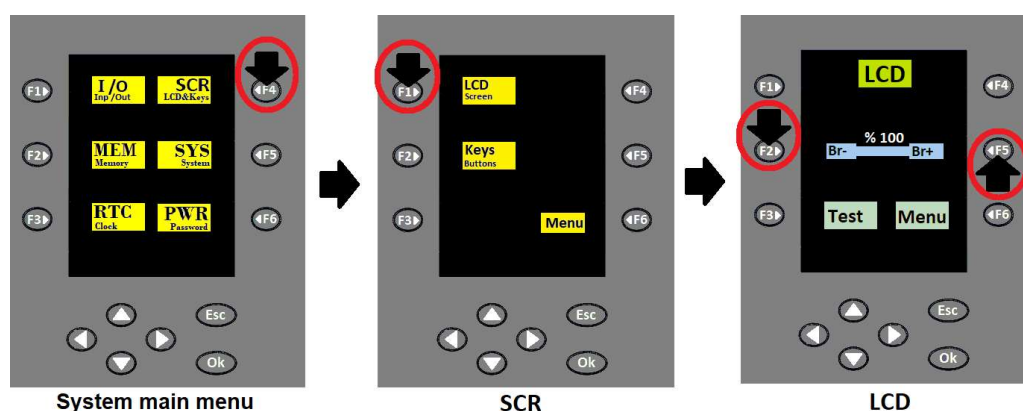

Figure - 26 Brightness adjustment

- In here gradual brightness adjustment from 100% to 10% can be made between "Br-" and "Br+". To increase the brightness by 10 gradually, press the "◀F5" key which is beside the "Br+". To decrease the brightness by 10 gradually, press the "F2▶" key which is beside the "Br-".
- The brightness is controlled by pressing the "F3▶" key which is beside the "Test". Pressing the same key again returns to the previous brightness setting menu.
- Pressing twice is enough to the "◀F6" key which is beside the "Menu" to return to the **system main menu**.

### 7.3.5.2 How do I test the 12-key to work properly?

- Press the “◀F4” key on the **system main menu** screen to enter the **SCR** screen. From here press the “F2▶” key which is beside the “**Keys (Buttons)**” should see the “**Key code 000**” on the screen. The proper working of the 12-keypad is tested here.
- **For example**; Pressing the “F1▶” key “**Key code 001**” appears on the display and pressing the “F2▶” key “**Key code 002**” appears on the display so that same for other keys; “F3▶” corresponds to **003**, “◀F4” corresponds to **004**, “◀F5” corresponds to **005**, “◀F6” corresponds to “**Menu**”, ◀ corresponds to **007**, ▶ corresponds to **008**, ▲ corresponds to **009**, ▼ corresponds to **010**, **Ok** corresponds to **011** and **Esc** corresponds to **012**. If a different value is seen, that means there is a fault.

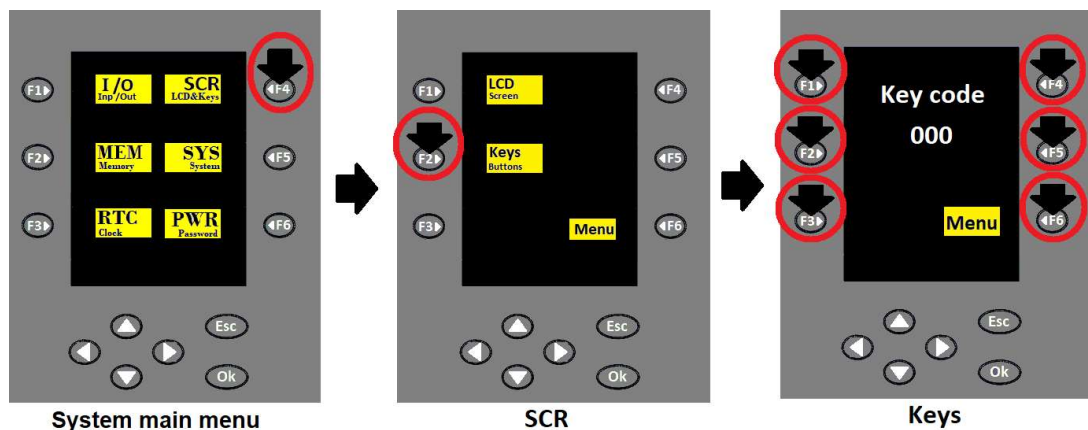

Figure - 27 Keypad proper working tests

- To return to the previous menu, press the “◀F6” key which is beside the “**Menu**” on the screen.

### 7.3.6 SYS (System)

- At the system main menu, when pressing the “◀F5” key (**SYS (System)**);



Figure - 28 SYS (System)

- As shown in **figure 28**, the system information such as **HWRev**, **Firmware**, **Bootloader**, **Model**, and **Status** are arranged in tabular form on the color display.
- Pressing once is enough to the “◀F6” key which is beside the “**Menu**” to return to the **system main menu**.

### 7.3.6.1 How Can I Get Status Information?

- As shown in **figure 29**, press the “◀F5” key which is beside the **SYS (System)** on the system main menu screen to get the system status information. System **status**, **model**, **bootloader**, **firmware** and **HWRev** hardware revision information are listed in the table.

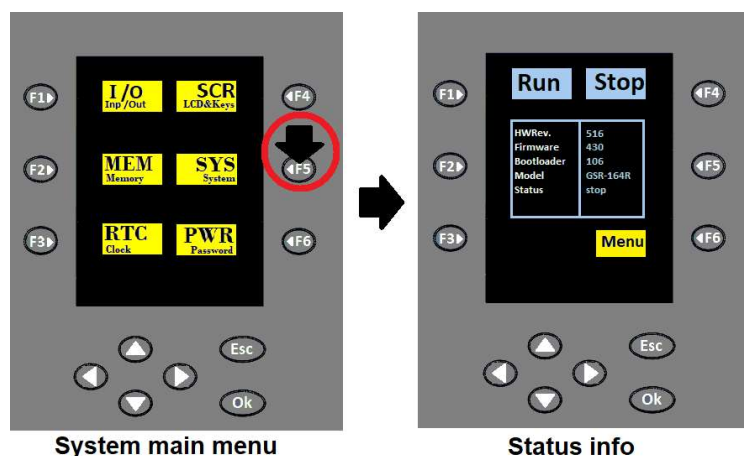

Figure - 29 Status info

- After the " Run " or " Stop " status of the system is received, optionally pressing the “F1▶” key ( RUN ) is commanded to run the system or pressing the “◀F4” key ( STOP ) is commanded to stop the system.
- When both keys (“F1▶” key ( RUN ) and “◀F4” key ( STOP )) are pressed “GSR Settings Password 00000” written is appears on the display. In this case, the password is entered into the " Password " field and the operation is continued.
- Pressing once is enough to the “◀F6” key which is beside the “ Menu ” to return to the system main menu.

### 7.3.7 PWD (Password)

- At the system main menu, when pressing the “◀F6” key (PWD (Password));



Figure - 30 PWD (Password)

- As shown in **figure 30**, “PASSWORD SET 00000” is appears on the screen.
- Pressing once is enough to the “◀F6” key which is beside the “ Menu ” to return to the system main menu.

### 7.3.7.1 How do I create a new password?

- As shown in **figure 31**, press the “◀F6” key which is beside the **PWD (Password)** on the **system main menu** screen to be renewed the device password.

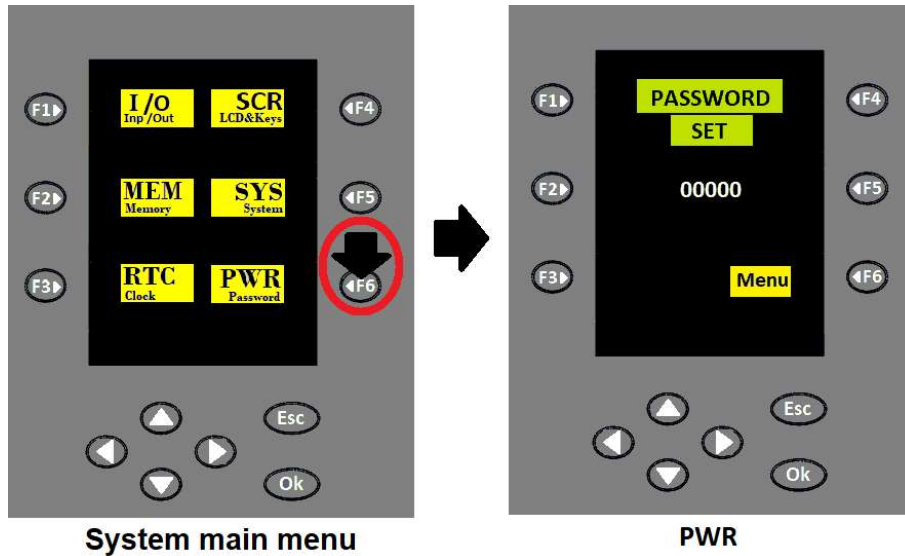

Figure - 31 Create new password

- Press the “◀F6” key which is beside the **PWD (Password)** the text “**PASSWORD SET 00000**” appears in the **figure 31**. The password of the **Mini PLC** create or renew or change here. The “**00000**” password typing field is activated with pressing **Ok** key. The new password is entered by using the **▲** and **▼** keys. The entered password is confirmed by pressing the **Ok** key again. A password must have a maximum length of 5 characters. The password can be assigned or edited only in the “**PWR (Password)**” menu. The menu cannot be accessed unless the password is entered correctly.

**PART**



**GMT**CNT

**GSR-164R**

## 8 MAINTENANCE & SUPPORT

- During the maintenance;



### Danger

Do not repair or service the appliance when it is power on. Otherwise there may be a risk of electric shock.

Electrical equipment should be repair and maintained only by qualified personnel. Otherwise doing so may result in damage to the device and injury.

### 8.1 Maintenance

- The effect of temperature, humidity, dust and vibration in the environment will cause aging of the components inside the device. This may cause the device to malfunction or reduce the life of the device. Therefore, routine and periodic maintenance of the device is required.
- **Maintenance of the device should be done in the following cases;**
  - 1) If there is an abnormal sound when the device is operating normally,
  - 2) If there is vibration during operation,
  - 3) If there is a change in the ambient conditions of the environment where the device is mounted,
  - 4) If the device is warmed up,
- **Routine cleaning;**
  - 1) The device must always be kept clean.
  - 2) Dust must be removed. Especially metal powder should be prevented from entering the device.
- **Periodic control;** Periodic control steps;
  - 1) Check the ventilation ducts and keep them clean.
  - 2) Check that the panel-mounted screws are missing.
  - 3) Check the cable connections for an electrical arc.

### 8.2 Warranty Information

- GMT Endüstriyel Elektronik San. ve Tic. Ltd. Şti., provides 2-year warranty against the damages caused by the operating conditions specified in the operating instructions. Out of this period the repair of malfunctions occurs for a fee.
- During the warranty period in the following cases repair of the devices will be done for a fee.
  - a) Damage caused if it is used out of conditions specified in the manual.
  - b) Damage caused by flood, fire and mains voltage fluctuations.



## 8.3 Support

- For quick and easy answers to your questions about **GSR164R Mini PLC**, please contact <http://forum.gmtcontrol.com>.

Technical support center contact information:

**Telephone:** +90 (216) 668 00 06, **GSM** +90 (534) 363 75 33

**Fax:** +90 (216) 668 00 08

**E-mail:** [gmt@gmtcontrol.com](mailto:gmt@gmtcontrol.com)

**Address:** Çubuklu Mh. Boğaziçi Cd. No:6/B Beykoz 34805 İstanbul, Türkiye.

## 8.4 User Review

Dear Customer,

- The reproduction, distribution or use of this document or its contents is not permitted without express written authority. Offenders will be liable for damages. All rights reserved, especially for the granting of patents.
- We have examined the contents of this publication for agreement with the hardware and software described. Nevertheless, discrepancies can not be ruled out. Any liability and warranty for the accuracy of this information is excluded. The data in this manual are reviewed at regular intervals. Any corrections required are included in the subsequent editions. Suggestions for improvement are welcomed.